



Also available with dial controls

Engineered for value.  
Designed for life.



**ENERGY STAR** rated refrigerator/freezer uses less energy, saves money and helps protect the environment



**Safe Plug™** technology limits electrical draw to under 10 amps for the combination appliance



**Action Wave** promotes faster, more uniform cooking with fewer hot and cold spots

**Model MF-3TP Combination Appliance Specifications\***

**Refrigerator**

ENERGY STAR rated for maximum energy-efficiency  
2.9 cu. ft. model  
Refrigerator volume: 2.13 cu. ft.  
Freezer volume: .75 cu. ft.  
Dimensions: 33 1/2"H x 18 5/8"W x 20 1/8"D

**Microwave oven**

.7 cu. ft., 700-watt microwave oven  
Dimensions: 10 5/8"H x 18 1/8"W x 12 13/16"D

**Combined unit dimensions**

44 1/8"H x 18 5/8"W x 20 1/8"D

**Weights**

Refrigerator.....58 lbs.  
Shipping weight.....65 lbs.  
Microwave oven.....26 lbs.  
Shipping weight.....29 lbs.

\* Model MF-3 for combination appliance with dial microwave

Model MFK-3 for 2-plug combination appliance (without circuitry)

Model MFR-3 for refrigerator/freezer only



**CUSTOM ENGINEERED FOR SAFETY AND CONVENIENCE**

**MicroFridge® with Safe Plug™ technology** – patented, current-limiting circuitry – requires only one dedicated circuit for the combination appliance.

**Blue plug** on the refrigerator plugs into the blue outlet on the back of the microwave for energy-efficient one-plug-to-the-wall operation.

**True zero-degree freezer** provides long-term food storage for ice cream and other frozen foods.

**Recessed, scoop handles** and rounded door design provides a sleek streamlined appearance to complement any décor.

**Full-width wire shelves** for easy cleaning.

**Door design** allows for upright storage of 2-liter bottles to minimize leaks and spills.

**Reversible doors** for flexibility in any installation.

**Mounting brackets** provide secure attachment of microwave to refrigerator/freezer.

**Microwave detaches** for custom installations and for servicing.

**Reduce cooking time** by 10% with efficient Action Wave energy distribution system.

**Unsurpassed warranty** underscores our quality product.

**Toll-free**, quick-response customer service.

**Available on GSA contract:** GS-21F-0091H.

**Available on AFNAF contract:** F41999-95-D-6071.

# Model MF-3TP

## REFRIGERATOR SPECIFICATIONS & FEATURES

Annual energy consumption.....290 kWh based on standard DOE test

ENERGY STAR qualified models use at least 10% less energy than required by current federal standards

### Electrical requirements

Power.....115 V/60 Hz

Start-up amps .....7.3

Normal operating amps.....1.4

Compressor watts.....75

### Exterior dimensions

Height .....33 1/2"

Width.....18 5/8"

Depth.....20 1/8"

Weight.....58 lbs.

Shipping weight.....65 lbs.

### Interior dimensions

Total volume.....2.9 cu. ft.

Refrigerator compartment volume.....2.13 cu. ft.

Freezer compartment volume.....0.75 cu. ft.

### Refrigerator features

- 2 full-width wire shelves
- 2 full-width door shelves
- 2-liter bottle door storage
- Temperature control
- Auto-defrost
- Interior light

### Freezer features

- Zero-degree freezer
- Manual defrost
- 1 ice cube tray
- Full-width door shelf

### Cabinet features

- Rounded, cambered door
- Coil back design
- Reversible door hinges
- Recessed/scoop door handles
- Leveling legs
- Available in black or white

## PRODUCT SCHEMATICS

### Minimum clearances

1" on each side, 2" in back, 1" on top

2-door 2.9 cu. ft. refrigerator/freezer and .7 cu. ft., 700-watt microwave oven

Top view with door swing\*

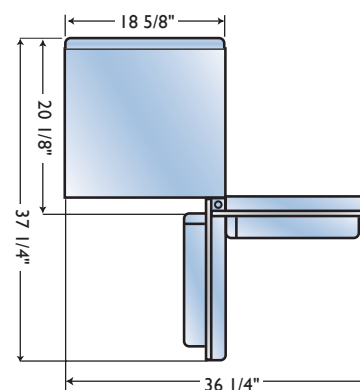

Front view, 2-door unit\*

Side view with coil\*

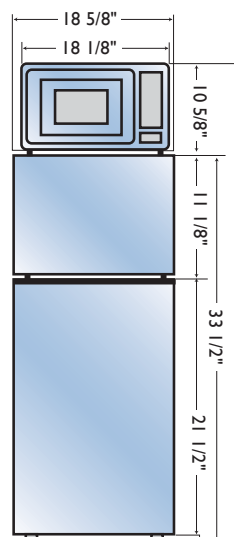

\*Drawings are not to scale.



**10 Walpole Park South  
Walpole, MA 02081**

**Ph: 800-994-0165 or 508 660-9200  
Fax: 800-231-2182 or 508-660-9242**

**www.microfridge.com**

**INTIRION.** "MicroFridge" and the MicroFridge logo are registered trademarks of Intirion Corporation, a subsidiary of Mac-Gray Corporation. "Safe Plug" and the Safe Plug logo are trademarks of Intirion Corporation. © Mac-Gray Corporation 2005.

## MICROWAVE OVEN SPECIFICATIONS & FEATURES

### Electrical requirements

Power.....120 V/60Hz

Power output, defrost.....350 watts

Power output, cook.....700 watts

Electrical draw.....8.1 amps

### Exterior dimensions

Height.....10 5/8"

Width.....18 1/8"

Depth.....12 13/16"

Weight.....26 lbs.

Shipping weight.....29 lbs.

### Interior dimensions

Oven capacity.....0.7 cu. ft.

### Microwave features

- Easy-grip pull door
- Removable 10 11/16" glass carousel
- Timer/auto shut-off
- Signal beeper
- Timer defrost
- Under counter mounting brackets available
- 5 ft. cord
- Available in black or white

### Additional Features on Electronic Touchpad Models:

- Programmed cooking options
- LED display and clock
- Available in black only

## ELECTRICAL REQUIREMENTS FOR COMBINATION UNIT

120 Volt, 2-Wire, 60 Hz, Single Phase (1PH), 1.2KW, 15 amp electrical supply

Our goal is to ensure complete customer satisfaction. To contact our quick-response customer service team, call 800-637-7567.

Specifications are subject to change. Please contact your sales representative for further details.



MicroFridge® complies with all UL requirements and EPA regulations to manufacture environmentally friendly refrigerators.



ENERGY STAR refrigerators use half the energy of a 10-year old model. Designed to meet strict energy-efficiency criteria, this ENERGY STAR rated refrigerator/freezer helps protect the environment.